NOTES

CONTENTS

1.0 Introduction	2
1.1 Available models	
2.0 Overview	3
2.1 Complete kit	
2.2 Operating elements	
2.3 Inserting batteries	
3.0 Measuring Procedures – LMI and LMC Models	5
3.1 Measuring with manual start/stop	
3.2 Setup	
3.3 Taking measurements	
4.0 Measuring Procedures – LMC-V and LMI-V Models	7
4.1 Measuring with manual start/stop	
4.2 Measuring with Automatic Start/Stop Signal	
4.3 Taking Measurements with Automatic Start / Stop Signal	
5.0 Specifications	10
6.0 Warranty	11



WARNING The device must not be operated in explosion hazard areas and must not come into contact with aggressive substances.

1.0 INTRODUCTION

CHECK•LINE LM Digital Consumption Meters accurately measure the amount of yarn being fed from a textile machine feeder to a take-up device during one or more cycles or rotations of the machine cylinder.

LM units are ideal for comparing yarn consumption from feed to feed and machine to machine on circular and flat bed knitting machines, and for other textile processes where yarn length is to be accurately measured.

1.1 Available models

Model	Range
LMC	9999,999 cm
LMC-V	9999,999 cm
LMI	9999,999 inches
LMI-V	9999,999 inches

7.0 WARRANTY

ELECTROMATIC Equipment Co., Inc. (ELECTROMATIC) warrants to the original purchaser that this product is of merchantable quality and confirms in kind and quality with the descriptions and specifications thereof. Product failure or malfunction arising out of any defect in workmanship or material in the product existing at the time of delivery thereof which manifests itself within one year from the sale of such product, shall be remedied by repair or replacement of such product, at ELECTROMATIC's option, except where unauthorized repair, disassembly, tampering, abuse or misapplication has taken place, as determined by ELECTROMATIC. All returns for warranty or non-warranty repairs and/or replacement must be authorized by ELECTROMATIC, in advance, with all repacking and shipping expenses to the address below to be borne by the purchaser.

THE FOREGOING WARRANTY IS IN LIEU OF ALL OTHER WARRANTIES, EXPRESSED OR IMPLIED, INCLUDING BUT NOT LIMITED TO, THE WARRANTY OF MERCHANTABILITY AND FITNESS FOR ANY PARTICULAR PURPOSE OR APPLICATION. ELECTROMATIC SHALL NOT BE RESPONSIBLE NOR LIABLE FOR ANY CONSEQUENTIAL DAMAGE, OF ANY KIND OR NATURE, RESULTING FROM THE USE OF SUPPLIED EQUIPMENT, WHETHER SUCH DAMAGE OCCURS OR IS DISCOVERED BEFORE, UPON OR AFTER REPLACEMENT OR REPAIR, AND WHETHER OR NOT SUCH DAMAGE IS CAUSED BY MANUFACTURER'S OR SUPPLIER'S NEGLIGENCE WITHIN ONE YEAR FROM INVOICE DATE.

Some State jurisdictions or States do not allow the exclusion or limitation of incidental or consequential damages, so the above limitation may not apply to you. The duration of any implied warranty, including, without limitation, fitness for any particular purpose and merchantability with respect to this product, is limited to the duration of the foregoing warranty. Some states do not allow limitations on how long an implied warranty lasts but, notwithstanding, this warranty, in the absence of such limitations, shall extend for one year from the date of invoice.

ELECTROMATIC Equipment Co., Inc.
600 Oakland Ave. Cedarhurst, NY 11516—USA
Tel: 1-800-645-4330/ Tel: 516-295-4300/ Fax: 516-295-4399

Every precaution has been taken in the preparation of this manual. Electromatic Equipment Co., Inc., assumes no responsibility for errors or omissions. Neither is any liability assumed for damages resulting from the use of information contained herein. Any brand or product names mentioned herein are used for identification purposes only, and are trademarks or registered trademarks of their respective holders.

5.0 SPECIFICATIONS

Measuring Range	LMC / LMC-V: 999999 cm LMI / LMI-V: 999999 inches
Resolution	LMC / LMC-V: 1 cm LMI / LMI-V: 1 inch
Accuracy	± 0.2% of reading, ± 1 digit
Measuring Principle	Pulse counting
Measuring Time	Continuously
Preselection	Only LMC-V / LMI-V: adjustable for 1 TO 99 revolutions
Display	LCD, .2 in (5 mm) high
Auto Power Off	After 2 minutes of non-use
Temperature Range	50 to 113 °F (10 to 45 °C)
Air Humidity	85% RH, max.
Power Supply	2 batteries 1.5 V, size AAA
Housing Material	Aluminum
Dimensions	Instrument: 6.3 x 2.7 x 2 in (160 x 55 x 51 mm) (L x W x H)
Magnetic base	Height (approx.) 7.48 in (190 mm), 1.57 in (40 mm) Ø
Weight	Instrument (approx.) 0.44 lb. (200 g) Magnetic base (approx.) 0.77 lb. (350 g) Complete with carrying case (approx.) 2.87 lbs. (1300 g)

2.0 OVERVIEW

2.1 Complete Kit

LMC / LMI

- Yarn Consumption Meter
- Magnetic base
- Operating instructions
- Carrying case
- Batteries (2)

LMC-V / LMI-V

- Yarn Consumption Meter
- Magnetic base
- Magnetic switch
- Magnet
- Operating instructions
- Carrying case
- Batteries (2)
- Screwdriver (2.5mm)

Complete Kit Photos?

2.2 Operating Elements

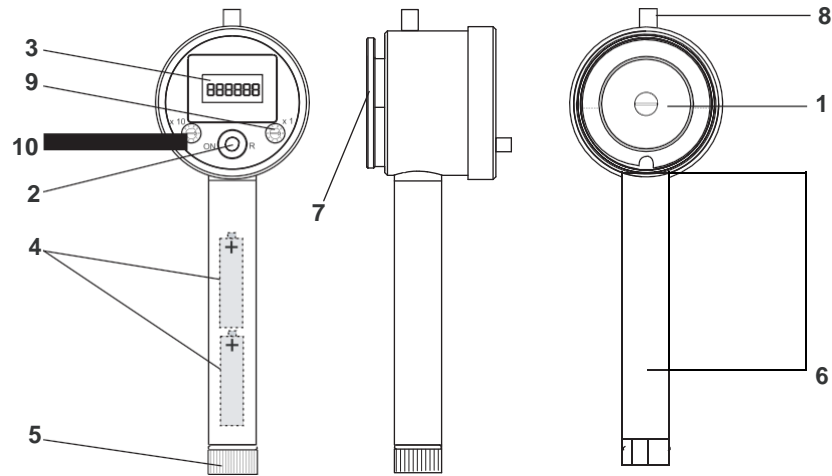

- | | |
|----------------------------|--|
| 1. Measuring Wheel | 6. Handle |
| 2. ON / RESET Switch | 7. Filament Guide Ring (LMC-V, LMI-V only) |
| 3. Display | 8. Connector for Magnetic Switch |
| 4. Batteries (2), 1.5V AAA | 9. Preset Switch x 1 |
| 5. End Cover | 10. Preset Switch x 10 |

2.3 Inserting The Batteries

Before first use of the instrument, the batteries four need to be inserted. If the display switches off while the instrument is running and the measuring wheel is rotating, the batteries 4 need to be replaced.

To insert the batteries:

1. Remove the end cover (5).
2. Insert the batteries into the battery compartment inside the handle. Please ensure proper polarity.
3. Screw the end cover back into the handle.

NOTE: If the instrument will not be used for an extended period of time, the batteries should be removed.

4.3 Taking Measurements with Auto Start / Stop Signal

1. Insert the material to be measured in the groove of the filament guide ring 7 on the rear side of the instrument. The filament guide ring can be turned by 360°.
2. Adjust the electronic yarn consumption meter in such a way that the angle of material contact with the measuring wheel is 120° minimum (see fig. 3.4d) to eliminate material slip.
3. Press the ON / RESET switch (see diagram on page 4).
4. As soon as the yarn consumption meter receives the first switching pulse from the magnetic switch, it starts counting the selected number of revolutions. Counting starts from 0.

The yarn consumption is also evaluated and shown on the display after the first switching pulse of the magnetic switch.

5. When the number of revolutions set with the preselect switches and has been reached, the instrument stops measuring.

The display shows the measured yarn consumption.

If a new yarn consumption measurement is necessary, repeat the measuring process from step 3 to ensure that the instrument has been reset.

NOTE: The electronic yarn consumption meter powers off automatically when the measuring wheel on the rear of the instrument has not been moving for about two minutes. The measured values are deleted.

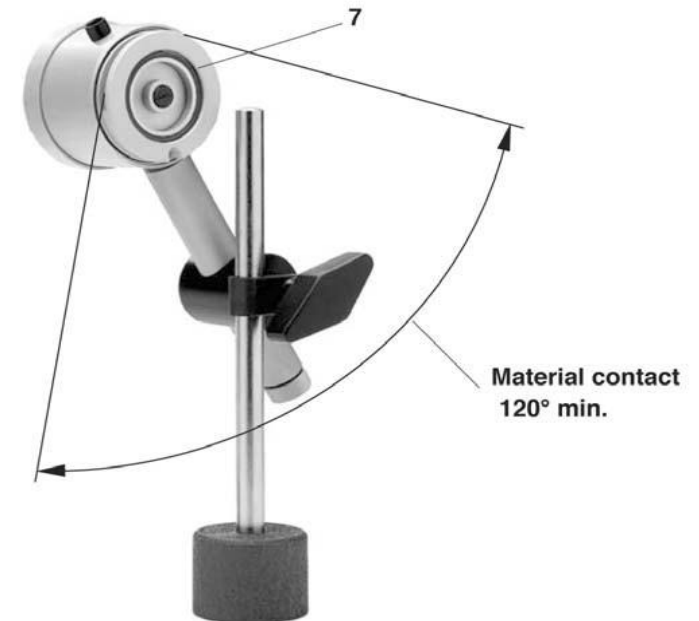

To select the number of revolutions:

00 = Manual Start / Stop

1 to 99 = Automatic Start / Stop Signal

Fig.5

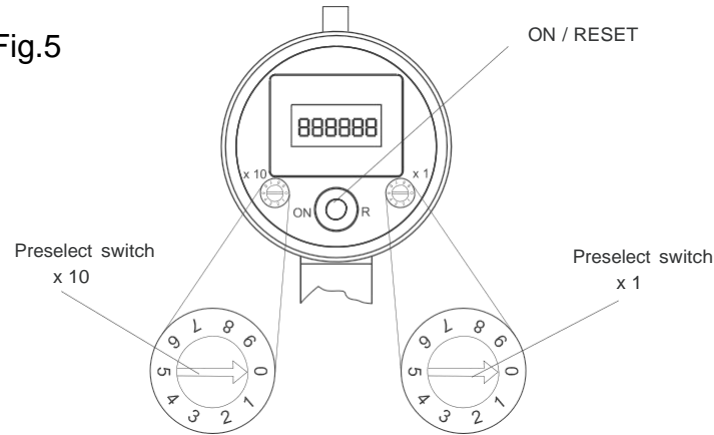

The preselect switches allow selecting the desired number of cylinder revolutions for the measuring cycle. The number of revolutions can be set from 0 to 99.

Preselection Example:

Desired number of revolutions = 54

Set preselect switch x10 to position 5.

Set preselect switch x1 to position 4.

NOTE: Use a fine screwdriver with a 2mm blade to set the preselect switches.

After every change of the setting of the preselect switches the ON / RESET switch must be pressed to activate the new setting.

3.0 MEASURING PROCEDURES WITH LMI AND LMC

3.1 Measuring with Manual Start /Stop

The Electronic Yarn Consumption Meter accurately measures the yarn consumption of a single yarn feeding system at a running knitting machine with fixed or rotating cylinders. The instrument is stationary mounted between filament break monitor and filament guides using the supplied magnetic base (see Fig. 1).

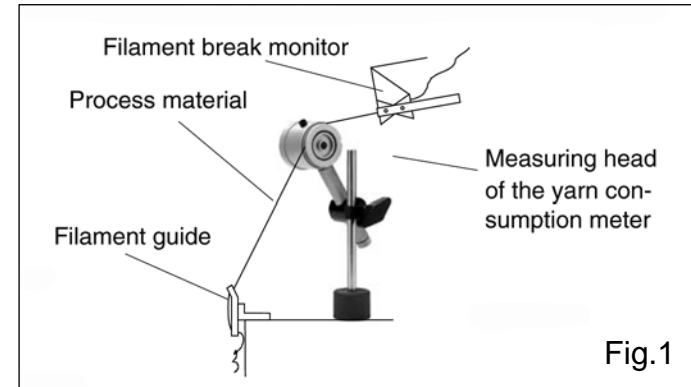

Fig.1

To eliminate material slip, adjust the electronic yarn consumption meter in such a way that the angle of material contact with the measuring wheel is 120° minimum (see Fig. 2). It is recommended to measure the yarn consumption for several machine cycles.

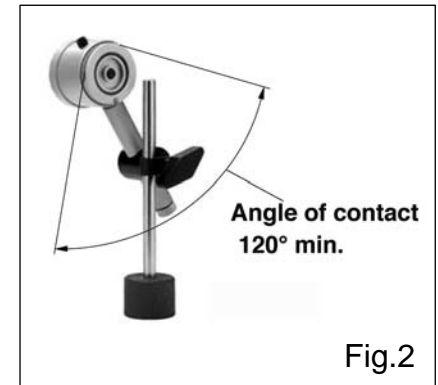
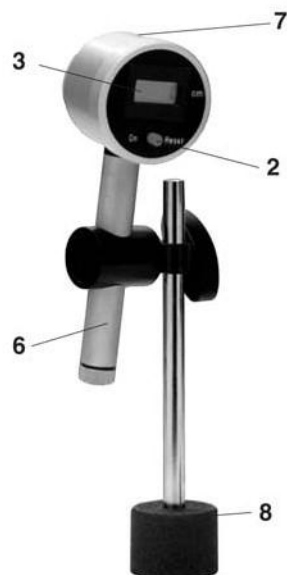

Fig.2

3.2 Setup

1. Place the magnetic base (8) at the desired measuring point.
2. Insert the handle (6) of the electronic yarn consumption meter in the holder of the magnetic base.
3. Insert the material to be measured in the groove of the filament guide ring (7) on the rear side of the instrument. The filament guide ring can be turned by 360°.
4. Adjust the electronic yarn consumption meter in such a way that the angle of material contact with the measuring wheel is 120° minimum (see Fig. 2) to eliminate material slip.

NOTE: The angle of material contact with the measuring wheel must be at least 120°.



3.3 Measuring Procedure (refer to diagram on page 4)

1. On the LMC-V and LMC-I models, set the preselect switches (9) and (10) to position 0, as shown in Fig. 4 on page 8.
2. Press the ON / RESET switch (2) to switch on the electronic yarn consumption meter.
3. Switch on the knitting machine for the desired number of machine cycles. The instrument now continuously measures the yarn consumption.
4. Switch off the knitting machine.
5. The display (3) now shows the measured length of yarn.

If a new yarn consumption measurement is necessary, repeat the complete Measuring Procedure

NOTE: The electronic yarn consumption meter powers off automatically when the measuring wheel on the rear of the instrument has not been moving for about two minutes. The measured values are deleted.

4.0 MEASURING WITH THE LMC-V AND LMI-V MODELS

4.1 Measuring with Manual Start /Stop

Follow the procedures outlined in section 3.0.

4.2 Measuring with Automatic Start/Stop Signal

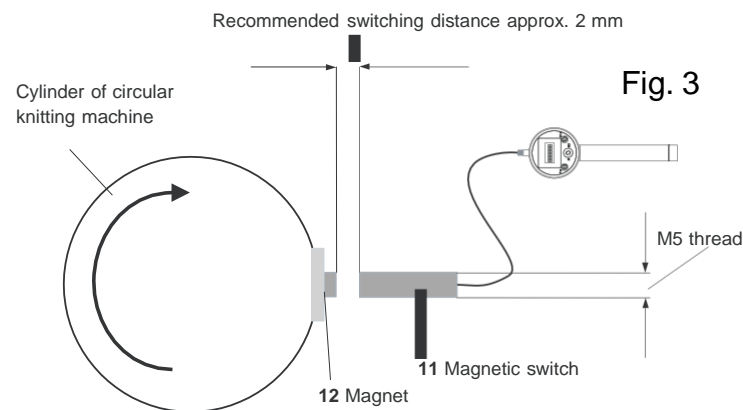

The LMC-V and LMI-V models feature an adjustable counter for up to 99 cylinder revolutions of the knitting machine. The cylinder revolutions are monitored by a magnetic switch.

To use this feature, the supplied magnet (12) must be mounted to the cylinder of the knitting machine by using an M5 flat head bolt. The supplied magnetic switch (11) is fitted to the stationary part of the knitting machine so that it is at the same height as the magnet (12) (see Fig. 4 below). The switching distance between the magnet and magnetic switch should be set to about 2mm with the adjusting nut and lock nut of the magnetic switch.

Mounting Example

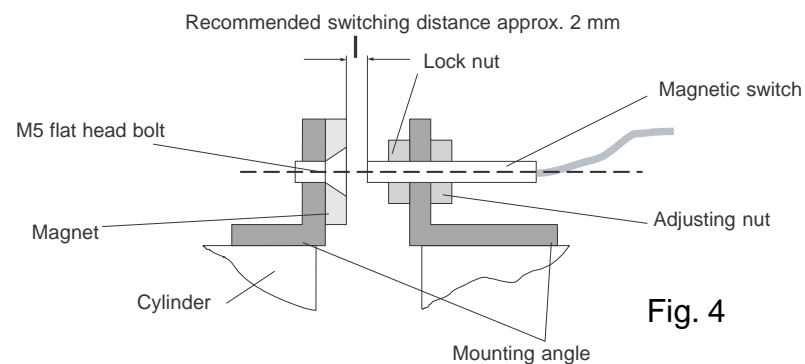

Fig. 4



YARN CONSUMPTION METER

LMI, LMI-V AND LMC, LMC-V

Operating Instructions



Power Tech International Group
sales@powertech-group.com
www.powertech-group.com